

## Beta-Cath™ 3.5F System

*A Second-Generation Platform*



### *New Radiation Source Train*

- Source Train diameter decreased to allow for a 3.5 F outer catheter diameter
- Equivalent radioactivity to original 5 F System
- “Jacketed” train design provides uniform dose distribution while maintaining flexibility to navigate tortuous vessels

### *New 3.5F Transfer Device*

- Provides full visibility of source train unit

### *New β-Rail™ 3.5F Delivery Catheter*

- Easily fits in a 6 F guide catheter
- Single catheter accommodates multiple source train lengths
- Allows access to distal anatomy
- 1 cm distal rapid exchange catheter

### *...Builds on the key advantages of the original Beta-Cath™ 5F System*

- Ideal low-maintenance Sr-90 Isotope
- Small, portable, hand-held device uniquely designed for the Cath Lab
  - Minimally flow-restrictive, passive-centered catheter design

## Jacketed Radiation Source Train

Isotope:	<sup>90</sup> Strontium
<sup>90</sup> Strontium Half-life:	28.8 years
Sealed Source Model/Dimensions:	AEAT-QSA Model SICW.2 2.5 mm x 0.38 mm (length x diameter)
Source Train Jacket:	Stainless Steel
30 mm Source Train:	2 Radiopaque Markers 12 Radioactive Sources
40 mm Source Train:	2 Radiopaque Markers 16 Radioactive Sources
Transfer Device Model:	A1767

Dose Rate and Activity: Activity and absorbed dose rate to water at 2mm from the Source Train is determined with a NIST traceable Source Train by Novoste and provided on the Novoste Calibration Certificate.

### Catalog numbers for ordering:

**CNK-0340**      **30 mm & 40 mm 3.5F Conversion Kit**  
**ABR-0340**      **β-Rail™ 3.5F Delivery Catheter**

### Beta-Cath™ 5F System and Beta-Cath™ 3.5F System

#### Beta-Cath™ 5F System Intended Uses

The Beta-Cath™ 5F System is intended to deliver beta radiation to the site of successful Percutaneous Coronary Intervention (PCI) for the treatment of in-stent Restenosis in native coronary arteries with discrete lesions (treatable with a 20 mm balloon for the 30 mm and 40 mm systems and injury areas up to 40 mm for the 60 mm system) in a reference vessel diameter ranging from 2.7 mm to 4.0 mm.

#### Beta-Cath™ 3.5F System Intended Uses

The Beta-Cath™ 3.5F System is intended to deliver beta radiation to the site of successful Percutaneous Coronary Intervention (PCI) for the treatment of in-stent Restenosis in native coronary arteries with discrete lesions (treatable with a 20 mm balloon) in a reference vessel diameter ranging from 2.7 mm to 4.0 mm.

#### Contraindications

- Unprotected left main disease (>50% narrowing).
- Patients in whom antiplatelet and/or anticoagulant therapy are contraindicated.

#### Warnings

- Every attempt should be made to avoid restenting of the target lesion to minimize the risk of thrombosis.

#### Delivery Catheter & Source Train Placement

- Use of an Internal Mammary (IM) Artery Guide Catheter may impede the path of the ACTIVE Source Train and may cause unintentional exposure of radiation and/or unintended results (Only for Beta-Cath™ 3.5F System).
- Vessel trauma may result from the improper use of the Delivery Catheter. Follow the enclosed directions carefully. When the Delivery Catheter is in the body, it should be manipulated only under fluoroscopy. Never advance or withdraw the Delivery Catheter against resistance without first determining the reason for the resistance under fluoroscopy.
- Failure to correctly position the Source Train at the injury site may underexpose the targeted treatment area and expose tissue not targeted for treatment to unintentional radiation. Exceeding the prescribed radiation treatment time will result in a higher than intended dose. Migration or improper location of the Source Train may cause unintentional radiation exposure to occur. The effect of unintentional radiation exposures and higher than intended doses are unknown.
- Do not over-tighten the hemostatic valve as this may damage the Delivery Catheter and impede the path of the Source Train and may cause unintentional exposure of radiation and/or unintended results.
- Upon return of the radiation source train, failure to open the hemostatic valve may prevent the radiation source train from returning to the device and may result in unnecessary radiation exposure to the patient or personnel.
- Failure to comply with the specific use of the Transfer Device controls may result in injury or unintended radiation exposure. Radiation is emitted from the Transfer Device when the Radiation Sources are in the Source Chamber. To minimize hand dose, the Transfer Device is designed to be held on the underside and may also be set down when appropriate.

#### Intravascular Radiation Procedure

- If the fluid in the capped Fluid Collection Bag after the procedure is found to be contaminated after scanning, then the Transfer Device and capped Fluid Collection Bag should be placed in the Temporary Storage Container. Immediately inform Institutional Radiation Safety personnel, implement contamination control procedures and call your Novoste Representative.
- If, at any time, a Survey Meter reading of the Transfer Device, Delivery Catheter, Fluid Collection Bag, or Procedure Room is significantly different from initial baseline readings, stop all activity and re-survey the Transfer Device, Delivery Catheter, Fluid Collection Bag, or Procedure Room making sure the fluoroscopy is off. If the reading is not within the acceptable baseline range or background range there may potentially be a misplaced source; refer to the Emergency Source Recovery Procedure in the System Instructions for Use.
- **UNDER NO CIRCUMSTANCES** should an individual attempt to remove the radiation source train from the Beta-Cath™ System, grasp the catheter directly with hands, cut the catheter, or pick up a source with his/her fingers, because unintended radiation exposure and injury may result. Required equipment is provided for this purpose in the Response Kit.
- Should breach of Source Train containment occur:
  1. Notify personnel present of missing source(s).
  2. Follow institutional procedures regarding personnel allowed to enter or leave the room until the source is contained.
  3. Individuals involved in source recovery should wear disposable gloves, an extremity dosimeter on the hand expected to receive the highest dose and a whole body dosimeter on the front of the body between the neck and the waist.

#### Precautions

- The Beta-Cath™ System is designed to be used by a team of appropriately trained personnel. At a minimum, this team should include a cardiologist, radiation oncologist, and medical physicist.

#### Beta-Cath™ System Preparation

- Prior to any procedure, the equipment should be thoroughly examined to verify the proper function and integrity of the system.
- Use the Delivery Catheter and Procedure Accessory Pack before the expiration date noted on the package. Verify that the sterility of the devices has not been compromised by assuring the package integrity has been maintained. The Delivery Catheter and Procedure Accessory Pack items are intended for single use. Do not re-sterilize and/or reuse these items.
- Do not use the Delivery Catheter if there is evidence of damage. If the Delivery Catheter Integrity Test detects a breach of catheter integrity, or restricted movement of the Source Train, note the observation and return the Source Train to the Transfer Device. Return the Delivery Catheter to Novoste Corporation. Prepare another Delivery Catheter for use.
- Handle the Transfer Device carefully and do not use if dropped. Do not use the Transfer Device if the controls and indicators are not functioning correctly or the LED light test is not observed. Do not begin a procedure if the Low Battery light is blinking. If the Low Battery Indicator starts blinking during a procedure, there will be enough battery power to complete the procedure.
- Do not use saline as a hydraulic fluid in the Transfer Device: corrosion may occur.
- The Transfer Device is not sterile. A sterile bag is provided to maintain a sterile field during the procedure. The inside portion of the tape covering the Syringe Port Hole and the Proprietary Connector Port Hole of the sterile bag is not sterile; remove from the sterile field.

## β-Rail™ 3.5F Delivery Catheter with Indicator of Source Train (IST)

Single use	
Sterile (by ethylene oxide) and Non-pyrogenic.	
Total Length/Working Length:	180 cm / 135 cm
Outer Diameter:	3.5 F (1.17 mm/0.046")
Indicator of Source Train:	Radiopaque 30 mm and 40 mm Radiation Train Length Markings
Guidewire Exit Port:	1 cm from distal tip of the Delivery Catheter
Catheter Markings:	
External Proximal Depth Marker:	100 cm from distal tip
Internal Radiopaque Marker (dark):	At Most Distal Point (Stop) of Source Train
Internal Radiopaque Tip Marker (light):	At Catheter Tip
Maximum Guidewire:	0.014" (0.36 mm)
Minimum Guiding Catheter:	6 F (1.7 mm/0.067") ID

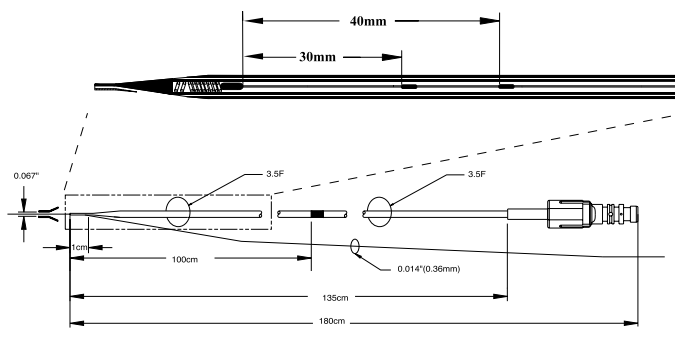

- Use Caution when connecting the Proprietary Connector to the Transfer Device. The Proprietary Connector of the Delivery Catheter is no longer sterile once disconnected from the Transfer Device.
- Use care when attaching components to the Transfer Device to ensure that the Sterile Bag does not get pinched in the process. Ensure a sufficient number of sterile water-filled syringes are available before beginning treatment. Always reserve at least 10 ml of sterile water for the return of the Source Train to prevent unintentional radiation exposure.
- Ensure that the Gate Control Switch is completely closed, as incomplete closure may render the Gate inoperable. Intravascular Radiation Procedure:
- Utilize a manual Blood Pressure Cuff to monitor patient status during the radiation treatment because arterial wave form pressure may be dampened while Delivery Catheter is in place.
- The Transfer Device contains radioactive material. Use of this device is restricted to persons licensed in the handling of radioactive materials. Personnel handling this device must follow the regulations, policies and procedures for their institution on the safety and hazards associated with radioactive materials.
- The individual performing the wipe and leak tests for radioactive material should use good contamination control techniques.
- If the transferable contamination exceeds 200 dpm/100 cm<sup>2</sup> (or the level determined by local regulation or institutional policy) or the leak test results exceed 11,100 dpm (or the level determined by local regulation or institutional policy) on any sample - place the contaminated object(s) in a plastic bag and label "Caution Radioactive Material." Immediately inform institutional Radiation Safety personnel, implement containment control procedures and call your Novoste Representative. Should this occur, do not continue with this procedure.
- Illumination of the Red Pressure Indicator light during a procedure indicates excessive pressure is being used - reduce applied pressure to return to the Amber Pressure Indicator area to avoid excess use of fluid.
- Do not turn the Transfer Device power On or attempt to open the Gate Control Switch during the Drying Procedure.
- Failure to perform adequate visual and radiation surveys post-procedure to verify source accountability may subject patients and/or personnel to unintended radiation exposure.
- The Transfer Device for the Beta-Cath™ 5F 30 mm and 40 mm System requires scheduled maintenance by Novoste Corporation every 250 procedures or six months, whichever event occurs first. The Transfer Device for the Beta-Cath™ 5F 60 mm System and the Beta-Cath™ 3.5F System requires scheduled maintenance by Novoste Corporation every 125 procedures or six months, whichever event occurs first.
- In the event a source becomes loose or needs to be transferred to a safe location, use the Source Recovery Tools with extreme care in source recovery. Improper use could damage sources and could potentially release unsealed radioactive material. Use of the Source Recovery Probe is the preferred method as it minimizes potential damage to a source restenosis.
- Avoid vessel or lesion morphologies that would preclude revascularization or placement of the Delivery Catheter.

#### Special Considerations

- As with other vascular brachytherapy procedures, safety and effectiveness has not been demonstrated in the following populations:
- Patients undergoing or having prior chest radiotherapy.
  - Patients unable to tolerate the recommended dwell time of the Source Train in the Delivery Catheter (5F).

#### Potential Adverse Events

- The following adverse events were NOT observed during the clinical investigation, but are recognized as potential adverse events associated with the non-radioactive portion of vascular brachytherapy include (not limited to):
- Arrhythmia • Arterial Damage, Dissection or Perforation • Vascular Access Site Hematoma • Contrast-Induced Nephrotoxicity • Neurologic Complications • Allergic Reactions • Infection • Stroke • Thrombotic Occlusion • Renal Insufficiency • Coronary Artery Bypass Graft Surgery • Slow Flow-Phenomenon • AV Fistula • Pseudoaneurysm • Left Ventricular Dysfunction • Systemic Atheroembolization • Endocarditis • Distal Embolizations • Vasospasm • Arterial Perforation • Retroperitoneal Hematoma

Additional potential Adverse Events associated with the radiation portion of vascular brachytherapy include, but are not limited to:

- Radiation Induced Malignancy • Aneurysm • Excessive radiation exposure to patient/staff • Arterial Damage • Coronary Artery Bypass Graft Surgery • Thrombosis • Restenosis • Myocardial Infarction • Death

Novoste, Beta-Cath, β-Cath, β-Rail, the Beta-Cath System logo design and the Beta-Cath 3.5F System logo design are trademarks of Novoste Corporation. U.S. Patent Numbers 5,683,345; 5,899,882; 6,013,020 and 6,261,219. Other patents pending. © 2002 Novoste Corporation. All rights reserved.

1-800-NOVOSTE • www.novoste.com  
(1-800-668-6783)